



A Right Choice For Professional Refrigeration



FROSTLINE

PRODUCT OF CONTINENTAL

Global Technology. Cool Solutions.

Frostline, a brand owned by Continental Group, brings to you International Quality Refrigerators using International Technology but Indian engineering to suit harsh conditions.

Frostline's plant, having automated European machines, produces vast range of products which are sold and installed all over India and various parts of the world including the Gulf, Africa and Asia.

Some of the most prominent features of FROSTLINE products are:

- Insulation PUF Injection System.
- Doors self closing and fitted with magnetic washable gasket.
- Doors are FLUSHED to avoid leakage.
- 60 mm thick insulation at very high density of 45 kg/cu mtr
- Monoblock, compact refrigeration system for reach ins
- Strong Structural Design
- Energy saving features and technology
- Hygiene friendly design
- European safety features
- Toughened & Vacuum Double walled Glass doors

The plant is situated at Chaupanki, Rajasthan, about 60 Km from Delhi. The plant houses state of the art Fabrication, Foaming and Refrigeration machinery and follows strict Quality control Systems and Processes using 5S techniques and ISO systems.

Frostline products are supported by strong service network of Continental that covers the entire country with centres in various locations.

Some of the customers using these products include:



Frostline - Chaupanki, Rajasthan



FROSTLINE

PRODUCT OF CONTINENTAL



Reach in Chillers and Freezers

- Forced Draft Cooling
- Mono block unit
- CFC / HFC Free
- High Density Insulation ~45 kg /cu. Mtr
- SS Interior & Exterior
- Available in four capacities 500/700/1000/1400 Ltr.
- Doors with locks
- Removable & washable Gaskets
- SS / Plastic Coated Shelves
- 60mm thick Insulation with injection system
- Rounded Corners, Bottom etc.
- Toughened Double walled Glass Door
- SS legs with 50mm Dia/Castors are Optional
- R404a Refrigerant



Mono Block
Compact Refrigeration System

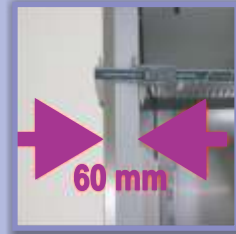

Insulation thickness 60
mm CFC & HCFC free.



Interior Stainless Steel AISI
304 Rounded corner
internal for easy cleaning



Wide magnetic gasket
gives effective seal and
is removable for easy cleaning



Tray slide adjustable at
60mm intervals



Completely removable
racking for easy cleaning

FROSTLINE

PRODUCT OF CONTINENTAL

Under Counter Chillers and Freezers

- Forced Draft Cooling
- 60mm thick Insulation with injection system
- CFC / HFC Free
- High Density Insulation ~45 kg /cu. Mtr
- SS Interior & Exterior
- Models with 2, 3 or 4 doors with locks
- Removable & washable Gaskets
- SS / Plastic Coated Shelves
- Drawers available as option
- Rounded Corners, Bottom etc.
- Toughened Double walled Glass Door
- SS legs with 50mm Dia/Castors are Optional
- R404a Refrigerant



Wide magnetic gasket gives effective seal and is removable for easy cleaning



Tray slide adjustable at 60mm intervals

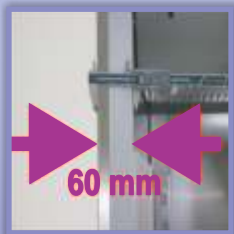

Insulation thickness 60 mm CFC & HCFC free.



UC2 / UF2



UC3 / UF3



UC4 / UF4

FROSTLINE

PRODUCT OF CONTINENTAL



PT2-3D



UC2SW



Drawer Unit

Pizza/Sandwich Prep Table

- Forced Draft Cooling
- 60mm thick Insulation with injection system
- CFC / HFC Free
- High Density Insulation ~45 kg /cu. Mtr
- SS Interior & Exterior
- Models with 2/3 doors with locks
- Removable & washable Gaskets
- SS GN Pan slides
- Rounded Corners, Bottom etc.
- Toughened Double walled Glass Door
- SS legs with 50mm Dia/Castors are Optional
- R404a Refrigerant



Stainless Steel interior.
Rounded corner internal for
easy cleaning



Dough-pan 600x400



Evaporating unit is installed
inside Undercounter.

FROSTLINE

PRODUCT OF CONTINENTAL

TECHNICAL DATA

RC7/RF7

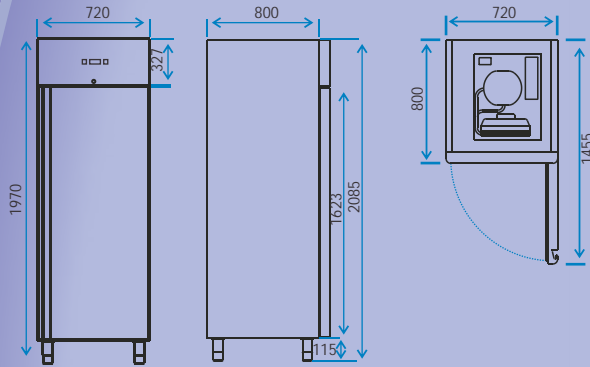

RC14/RF14

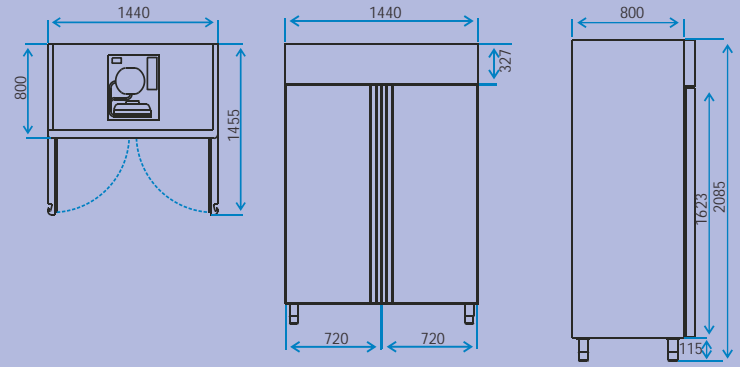

UC2/UF2

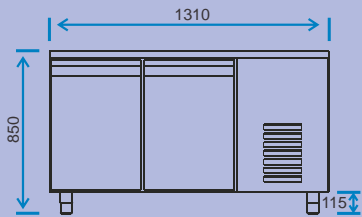

UC3/UF3

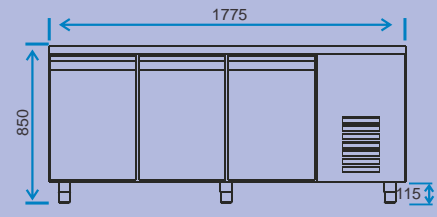



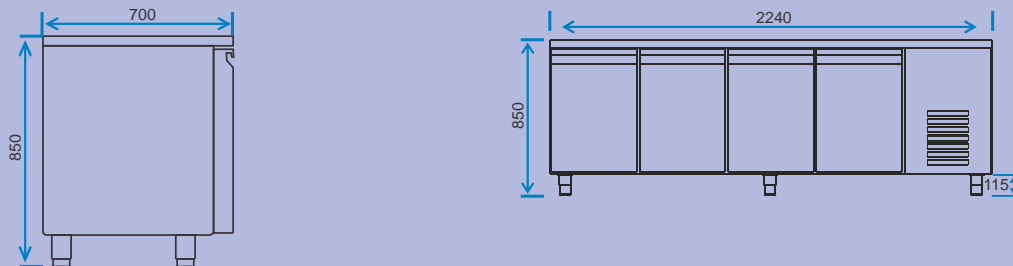



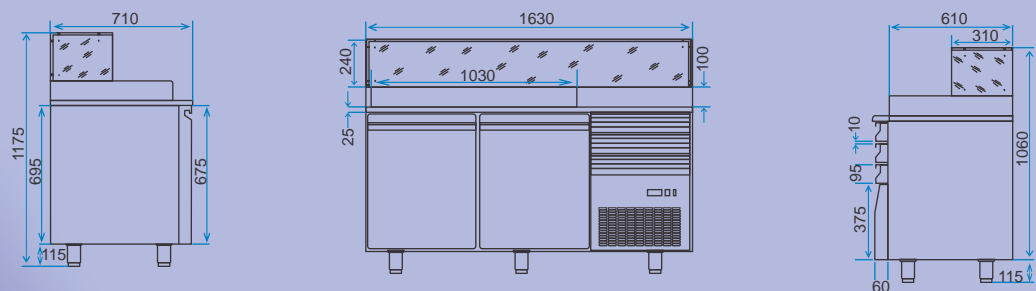

UC4/UF4











2 Door Sandwich Counter













SPECIFICATION

Model	 Temperature	 Capacity	 Voltage	 Abs. Power	 Dimensions	 Packing Dim.	 Shelves	 Ambient Temp.	 Weight
	°C	Lt	Volt/Hz	Watt	WxDxH cm	WxDxH cm	N°	°C	Kg
RC5	-2° +8°	485	220-240/50	270	72x70x212	79x76x228	3	+43	120
RF5	-10° -20°	485	220-240/50	670	72x70x212	79x76x228	3	+43	130
RC5-G	-2° +8°	485	220-240/50	370	72x70x212	79x76x228	4	+43	140
RF5-G	-10° -20°	485	220-240/50	1000	72x70x212	79x76x228	4	+43	140
RC7 / RC7-2	-2° +8°	700	220-240/50	277	72x80x212	79x86x228	3/4	+43	120
RF7 / RF7-2	-10° -20°	700	220-240/50	681	72x80x212	79x86x228	3/4	+43	130
RC7-G	-2° +8°	700	220-240/50	376	72x80x212	79x86x228	4	+43	140
RF7-G	-10° -20°	700	220-240/50	1037	72x80x212	79x86x228	4	+43	160
RC10	-2° +8°	1066	220-240/50	340	144x70x212	148x76x228	6	+43	190
RF10	-10° -20°	1066	220-240/50	1000	144x70x212	148x76x228	6	+43	200
RC10-G	-2° +8°	1066	220-240/50	480	144x70x212	148x76x228	8	+43	225
RF10-G	-10° -20°	1066	220-240/50	1800	144x70x212	148x76x228	8	+43	225
RC14/RC14-4	-2° +8°	1400	220-240/50	346	144x80x212	148x86x228	6/8	+43	190
RF14/RF14-4	-10° -20°	1400	220-240/50	1082	144x80x212	148x86x228	6/8	+43	200
RC14-G	-2° +8°	1400	220-240/50	476	144x80x212	148x86x228	8	+43	235
RF14-G	-10° -20°	1400	220-240/50	1855	144x80x212	148x86x228	8	+43	260



Model	 Temperature	 Capacity	 Voltage	 Abs. Power	 Dimensions	 Packing Dim.	 Shelves	 Ambient Temp.	 Weight
	°C	Lt	Volt/Hz	Watt	WxDxH cm	WxDxH cm	N°	°C	Kg
UC2	-2° +8°	275	220-240/50	298	131x70x85	135x74x100	2	+43	110
UC3	-2° +8°	428	220-240/50	372	177,5x70x85	182x74x100	3	+43	155
UC4	-2° +8°	581	220-240/50	418	224x70x85	228x74x100	4	+43	185
UF2	-10° -20°	275	220-240/50	565	131x70x85	135x74x100	2	+43	115
UF3	-10° -20°	428	220-240/50	708	177,5x70x85	182x74x100	3	+43	160
UF4	-10° -20°	581	220-240/50	752	224x70x85	228x74x100	4	+43	190



Model	 Temperature	 Capacity	 Voltage	 Abs. Power	 Dimensions	 Packing Dim.	 Nr. Pans	 Ambient Temp.	 Weight
	°C	Lt	Volt/Hz	Watt	WxDxH cm	WxDxH cm	Not included	°C	Kg
PTS2-3D	-2° +8°	350	220-240/50	253	164x71x85+35	176x81x110	6 GN 1/4	+43	180
Sandwich Table							GN Pans 		
UC2SW	+2 +10°	236	220-240/50	321	131x70x101	135x74x116	9 GN 1/9	+43	
UC3SW	+2 +10°	367	220-240/50	372	177.5x70x101	182x74x116	13 GN 1/9	+43	



FROSTLINE

PRODUCT OF CONTINENTAL

FROSTLINE

PRODUCT OF CONTINENTAL

Nation-wide Network

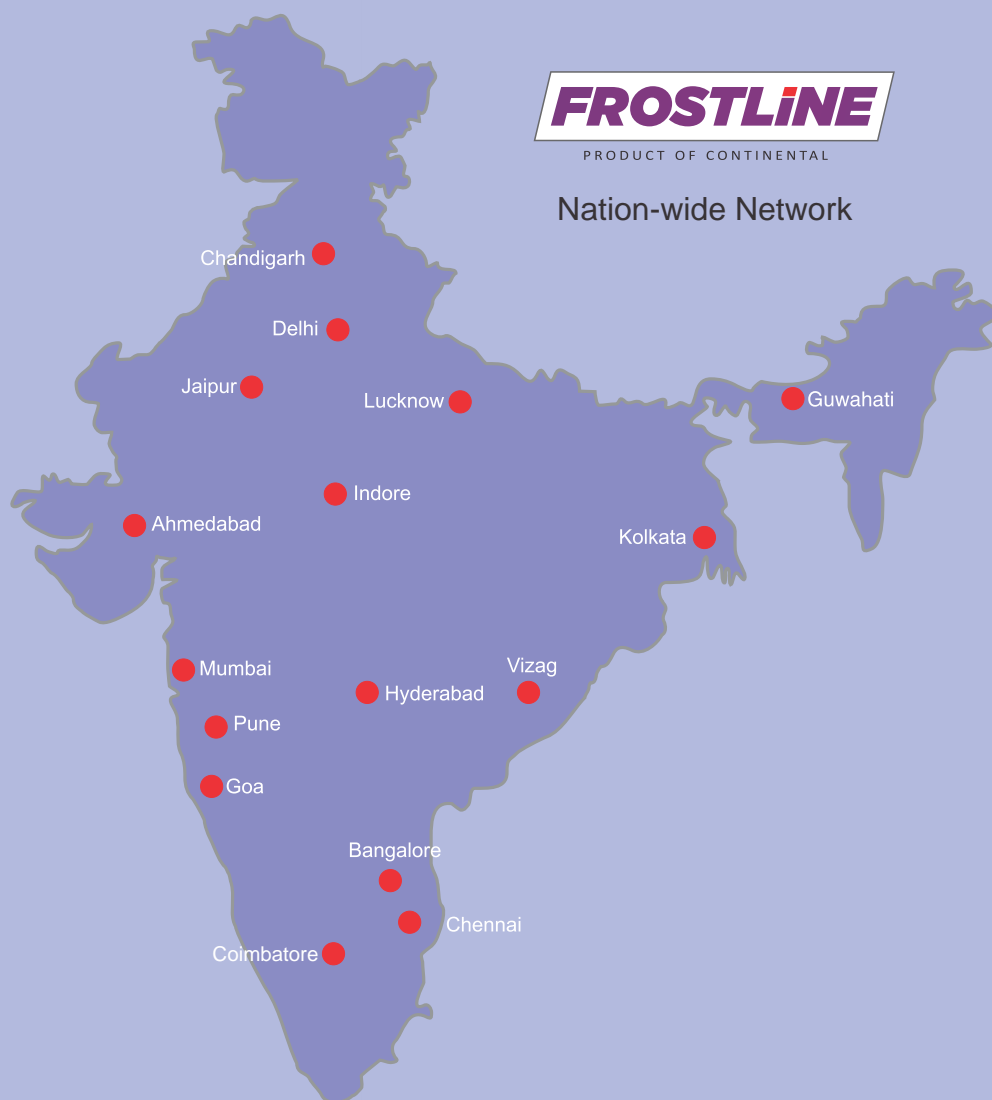

Continental Frostline (India) Pvt. Ltd.

Sales Office:

“Continental House”
76-F, Udyog Vihar Phase-IV
Gurgaon, Haryana - 122 015, India
Phone: +91-124-4920700 (20 Lines)
Fax: +91-124-4014189
Email: sales@frostline.co.in

Works:

E 541, RIICO Industrial Area
Chaupanki, Distt. Alwar - 301 017
Rajasthan, India
Phone: +91-1493-305450- 305466

Also installed in

Bangladesh
Ghana
Maldives
Nigeria
Seychelles
Singapore
Sri Lanka

We reserve the right to change the specifications without prior notice.